

Connection diagramm LaserProbe4500

The 3D- laserscanning system LaserProbe4500 is pre-configured for our routers.

Connection diagramm:

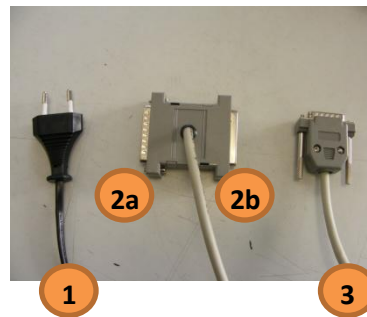
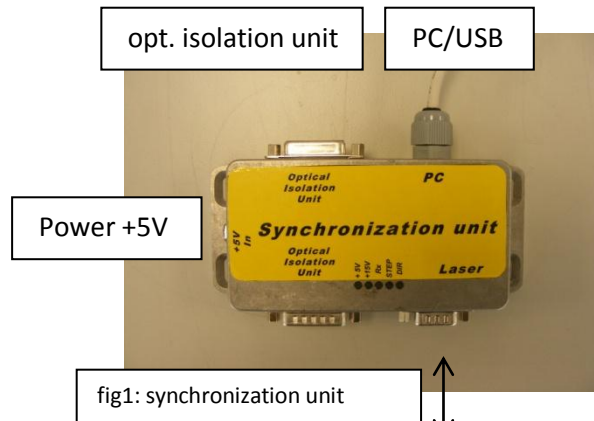

1	Power ~110-220V	
2a	Connection with machine control (LPT-Port)	25pol.
2b	Software: WinPCNC Light / Economy – connection with LPT-Port PC WinPCNC USB – connection with USB-Box (ncUSB – LPT1) WinPCNC Profi – connection with axis-controller (CNC-Control – LPT)	25pol.
3	Connection with synchronization unit	15pol.